

RefleX Protection and Control

RefleX - 1500

3 phase overvoltage protection
3 phase undervoltage protection
Communication (IEC 60 870-5-103)



2-stage overvoltage
2-stage undervoltage
Model 1500

RefleX Overvoltage and Undervoltage Protection

Menu setting group #1

OV, UV U1 12.7kV U2 12.7kV U3 12.7kV		In-service display Voltage U1 primary value Voltage U2 primary value Voltage U3 primary value
Trip records	(See separate description of the sub-menu 'Trip Records')	Press 'enter' to display recorded data After selecting a record use 'arrow up' or 'arrow down' to display additional information. Leave monitor by pressing 'Esc'.
U> #1 U> 14000/70.0V t> 1.50s VT 22000/110V	_____ _____ _____	U> voltage Setting group # Primary/secondary overvoltage set value Trip delay Primary/secondary VT.
U>> #1 U>> 15200/76.0V t>> 0.500s VT 22000/110V	_____ _____ _____	U>> voltage Setting group # Primary/secondary overvoltage set value Trip delay Primary/secondary VT.
t<0.050s #1 U< 10000/50.0V Limit 3000/15.0V VT 22000/110V	_____ _____ _____	Trip delay Setting group # Primary/secondary undervoltage set value Lower limit for undervoltage detection Primary/secondary VT.
t<<0.050s #1 U<< 9000/45.0V Limit 3000/15.0V VT 22000/110V	_____ _____ _____	Trip delay Setting group# Primary/secondary undervoltage set value Lower limit for undervoltage detection Primary/secondary VT.
Comm. IEC ON Config. Ring Address 1 Meas. value 1.2	_____ _____ _____	Configuration Comm. On/Off Relay address Value of measurand
YMD 2002-08-13 HMS 13:52:36 Password **** Freq. 50Hz	_____ _____ _____	Year-month-day 24 hour clock Four-digit password Rated power system frequency

*) If the VT is delta connected on the secondary or primary side, or if the relay is delta connected, please note that phase to earth measurement is not applicable.

RefleX Overvoltage and Undervoltage Protection

Menu setting group #2

OV, UV U1 12.7kV U2 12.7kV U3 12.7kV		In-service display Voltage U1 primary value Voltage U2 primary value Voltage U3 primary value
Trip records	(See separate description of the sub-menu 'Trip Records')	Press 'enter' to display recorded data After selecting a record use 'arrow up' or 'arrow down' to display additional information. Leave monitor by pressing 'Esc'.
U> #2 U> 14000/70.0V t> 1.50s VT 22000/110V	_____ _____ _____	U> voltage Setting group # Primary/secondary overvoltage set value Trip delay Primary/secondary VT.
U>> #2 U>> 15200/76.0V t>> 0.500s VT 22000/110V	_____ _____ _____	U>> voltage Setting group # Primary/secondary overvoltage set value Trip delay Primary/secondary VT.
t<0.050s #2 U< 10000/50.0V Limit 3000/15.0V VT 22000/110V	_____ _____ _____	Trip delay Setting group # Primary/secondary undervoltage set value Lower limit for undervoltage detection Primary/secondary VT.
t<<0.050s #2 U<< 9000/45.0V Limit 3000/15.0V VT 22000/110V	_____ _____ _____	Trip delay Setting group# Primary/secondary undervoltage set value Lower limit for undervoltage detection Primary/secondary VT.
Comm. IEC ON Config. Ring Address 1 Meas. value 1.2	_____ _____ _____	Configuration Comm. On/Off Relay address Value of measurand
YMD 2002-08-13 HMS 13:52:36 Password **** Freq. 50Hz	_____ _____ _____ _____	Year-month-day 24 hour clock Four-digit password Rated power system frequency

*) If the VT is delta connected on the secondary or primary side, or if the relay is delta connected, please note that phase to earth measurement is not applicable.

RefleX Overvoltage and Undervoltage Protection

Trip records

After a relay trip the display showing date and time of the trip automatically appears.

Each trip is automatically assigned a separate serial number.

All displays show recordings subsequent to relay tripping. The last five recordings are always stored.

By using arrow up/arrow down the user may access all relevant information in the displays below.

Only trip records (displays) with active information is stored and/or displayed after a trip.

Trip records

```
Trip 333
2002-08-13
12:13:14.123
Delay 0.50s
```

```
Trip 333
U>          U>>*
U<          U<<
```

```
Trip 333
U1          16,2kV
U2          16,2kV
U3          16,2kV
```

This display is part of the main menu
After selecting a record use 'arrow up' or 'arrow down' to display additional information.
Leave trip records by pressing 'Esc'.

Header (in this case looking at trip no. 333)

Date of 'trip 333'

Time of 'trip 333'

Delay of 'trip 333'

Trip 333

* indicates type of trip

Trip 333

Primary phase voltage U1

Primary phase voltage U2

Primary phase voltage U3

Reflex Overvoltage and Undervoltage Protection

Logic diagram

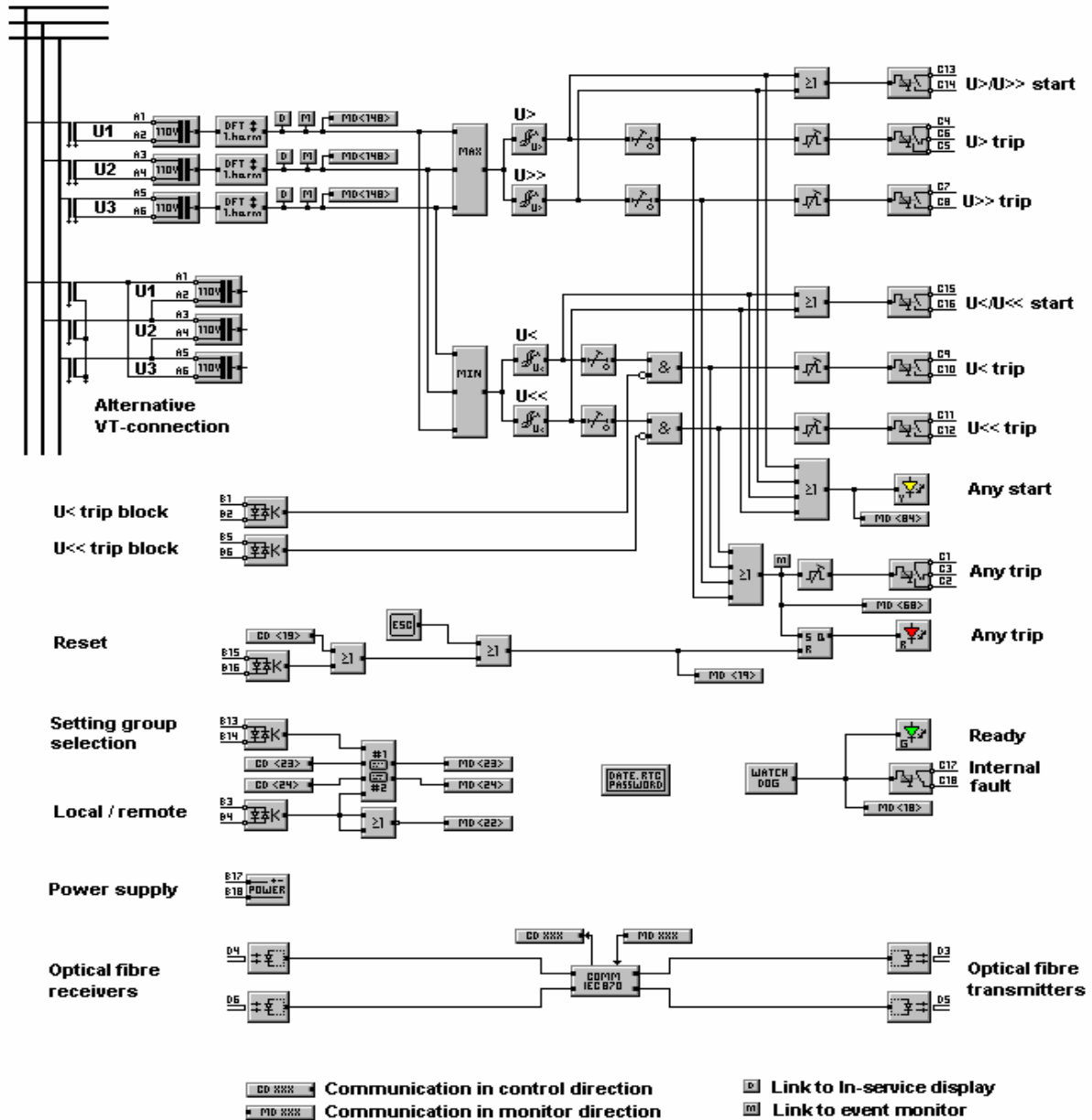

Source file: 1500_PRD_110b_UK.bmp

RefleX Overvoltage and Undervoltage Protection

Technical data

Overvoltage protection

Measurement		3 phases
Overvoltage settings	U> , U>>	1.00 - 170 V and block
Definite time settings	t> , t>>	0.01 - 999 s and block
Resetting ratio		>0.97
Harmonic measurement		1st harmonic

Undervoltage protection

Measurement		3 phases
Undervoltage settings *)	U< , U<<	1.00 - 170 V and block
Lower limit for undervoltage detection	Limit	1.00 - 99 V and block
Definite time settings	t< , t<<	0.01 - 999 s and block
Resetting ratio		<1.03
Harmonic measurement		1st harmonic
*) The undervoltage levels have to be set higher than the lower limit for undervoltage		

Selection between two setting groups

Setting group #1 is active when 'low' input voltage is applied to	Input B13-B14
Setting group #1 could also be selected by signal from comm.	<CD 23>
Setting group #2 is active when 'high' input voltage is applied to	Input B13-B14
Setting group #2 could also be selected by signal from comm.	<CD 24>
Setting group is selected by communication when 'high' input voltage is applied to	Input B3-B4

System data

Factory default password	1111
Pulse-extension circuit on all trip outputs	0.2 s pulse
Rated frequency	50 / 60 Hz

Communication (IEC 60 870-5-103 protocol)

Optical fibre transmitters	Outputs D3, D5
Optical fibre receivers	Inputs D4, D6

Selection of standard information numbers in monitor direction (MDxxx)

	Type	Info.no	ASDU	Gi
Protection inactive (internal fault)	160	18		x
LED-reset	160	19		-
Local parameters ON	160	22		x
Characteristic 1 (selected setting group)	160	23		x
Characteristic 2 (selected setting group)	160	24		x
General trip	160	68		-
General start	160	84		x
Measurands IL1,2,3	160	148		-

Selection of standard information numbers in control direction (CDxxx)

LED-reset	160	19
Select setting group 1	160	23
Select setting group 2	160	24